

OSI VERSATILE DIGITAL PANEL METER

MODEL 15660

DESCRIPTION

The 15660 is a streamlined, low-cost, utility, dc voltage measuring meter. The unit has a standard input range of $\pm 2V$. The easy-to-use screw terminals and provision to "Hold" the displayed reading indefinitely make this a cost-effective solution for display of most analog signals.

Ease-of-use and quick installation are facilitated by the unique pinout of the series. The standard meter is provided with screw terminal blocks and insulated quick disconnects.



FEATURES

- 0.56" LED Display
- Screw Terminals for Easy Connection
- Selectable Decimal Point Position

SPECIFICATIONS

INPUT

Voltage Range..... Standard $\pm 2Vdc$
 Selectable 20Vdc, $\pm 200Vdc$
 Impedance..... 1M Ω , minimum

INSTRUMENT POWER

Standard..... 120/240V, 50/60Hz, 2.5VA

DISPLAY 0.56" LED Display

ACCURACY $\pm 0.05\%$ of reading + 3 digits

TEMPERATURE

Operating Range -10°C to +50°C

CASE DIMENSIONS in inches (mm)

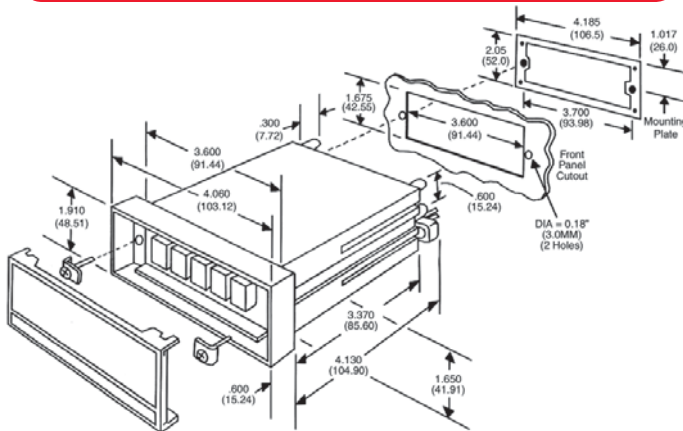

CONNECTION DIAGRAM

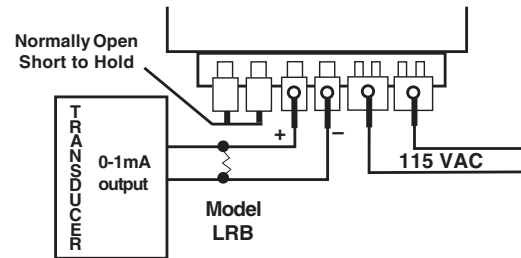

Dwg# 0902-00894-B Rev --

MINIATURE ELECTRONIC COUNTER

MODEL 13835

FEATURES

- 8 Digits, 0.354" (9mm) LCD Display
- Reset Front and Remote
- 10-Year Battery
- Relay Contact/Open Collector/5V TTL or CMOS Pulse Input
- Up to 10kHz Count Rate
- NEMA 4X/IP65 Rating Kit includes additional mounting adapters.



CONNECTION DIAGRAM

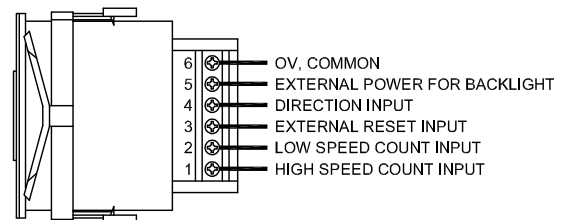

Dwg# 0902-00893-B Rev --

CASE DIMENSIONS (in inches)

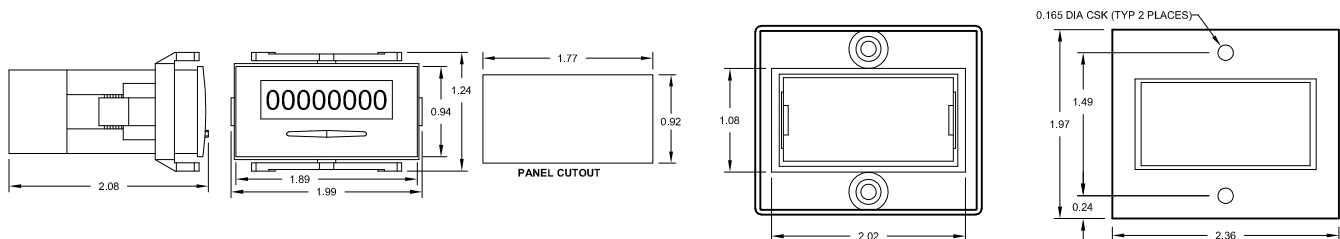

Counter can be mounted as shown in drawing, or with included adaptor plate as shown in photo, or with adaptor frame - Consult factory for details.

OHIO SEMITRONICS, INC.

4242 REYNOLDS DRIVE * HILLIARD, OHIO * 43026-1264
 PHONE: (614) 777-1005 * FAX: (614) 777-4511
 WWW.OHIOSEMITRONICS.COM * 1-800-537-6732